



**HAL**  
open science

## The Two Phases of HIV-1 Group O Diversification

Marie Leoz, Felix Feyertag, Anfumbom K. W. Kfutwah, Philippe Maucière, Guillaume Lachenal, Florence Damond, Veronique Lemée, François Simon, David L Robertson, Jean-Christophe Plantier

► **To cite this version:**

Marie Leoz, Felix Feyertag, Anfumbom K. W. Kfutwah, Philippe Maucière, Guillaume Lachenal, et al.. The Two Phases of HIV-1 Group O Diversification. IRIB, Jun 2015, Rouen, France. hal-02116005

**HAL Id: hal-02116005**

**<https://normandie-univ.hal.science/hal-02116005v1>**

Submitted on 30 Apr 2019

**HAL** is a multi-disciplinary open access archive for the deposit and dissemination of scientific research documents, whether they are published or not. The documents may come from teaching and research institutions in France or abroad, or from public or private research centers.

L'archive ouverte pluridisciplinaire **HAL**, est destinée au dépôt et à la diffusion de documents scientifiques de niveau recherche, publiés ou non, émanant des établissements d'enseignement et de recherche français ou étrangers, des laboratoires publics ou privés.

Marie Leoz<sup>1,2\*</sup>, Felix Feyertag<sup>3</sup>, Anfumbom Kfutwah<sup>4</sup>, Philippe Maucière<sup>5</sup>, Guillaume Lachenal<sup>6</sup>, Florence Damond<sup>7</sup>, Véronique Lemée<sup>8</sup>, François Simon<sup>9</sup>, David L Robertson<sup>3</sup>, Jean-Christophe Plantier<sup>1,2, 8</sup>

<sup>1</sup>Laboratoire de Virologie, CHU Charles Nicolle, Rouen, France; <sup>2</sup>EA 2656 GRAM, Université de Rouen, Rouen, France; <sup>3</sup>Computational and Evolutionary Biology, Faculty of Life Sciences, University of Manchester, Manchester, UK; <sup>4</sup>Service de Virologie, Centre Pasteur du Cameroun, Yaoundé, Cameroun; <sup>5</sup>Direction Interarmées du Service de Santé, Nouméa, Nouvelle Calédonie; <sup>6</sup>Laboratoire SPHERE, UMR 7219, Université Paris Diderot & Institut Universitaire de France, Paris, France; <sup>7</sup>Service de Virologie, APHP CHU Bichat Claude Bernard, Paris, France; <sup>8</sup>Laboratoire associé au Centre National de Référence du VIH, CHU Charles Nicolle, Rouen, France; <sup>9</sup>Service de Virologie, APHP CHU Saint Louis, Paris, France

## BACKGROUND

HIV-1 is subdivided into **4 groups**: M, O, N and P.

Each group represents an independent **cross-species transmission** of SIV (Simian Immunodeficiency Viruses) to humans.

Group M is **pandemic** : >34,000,000 infections worldwide;

Groups N and P **very rare**: <20 infections linked to Cameroon;

Group O is **endemic in Cameroon**: ~ 10,000 to 30,000 infections.

Group O MRCA (Most Recent Common Ancestor) has been estimated to be **as ancient as group M** based on few sequences available. But group O genetic diversity and evolution remains poorly characterized.

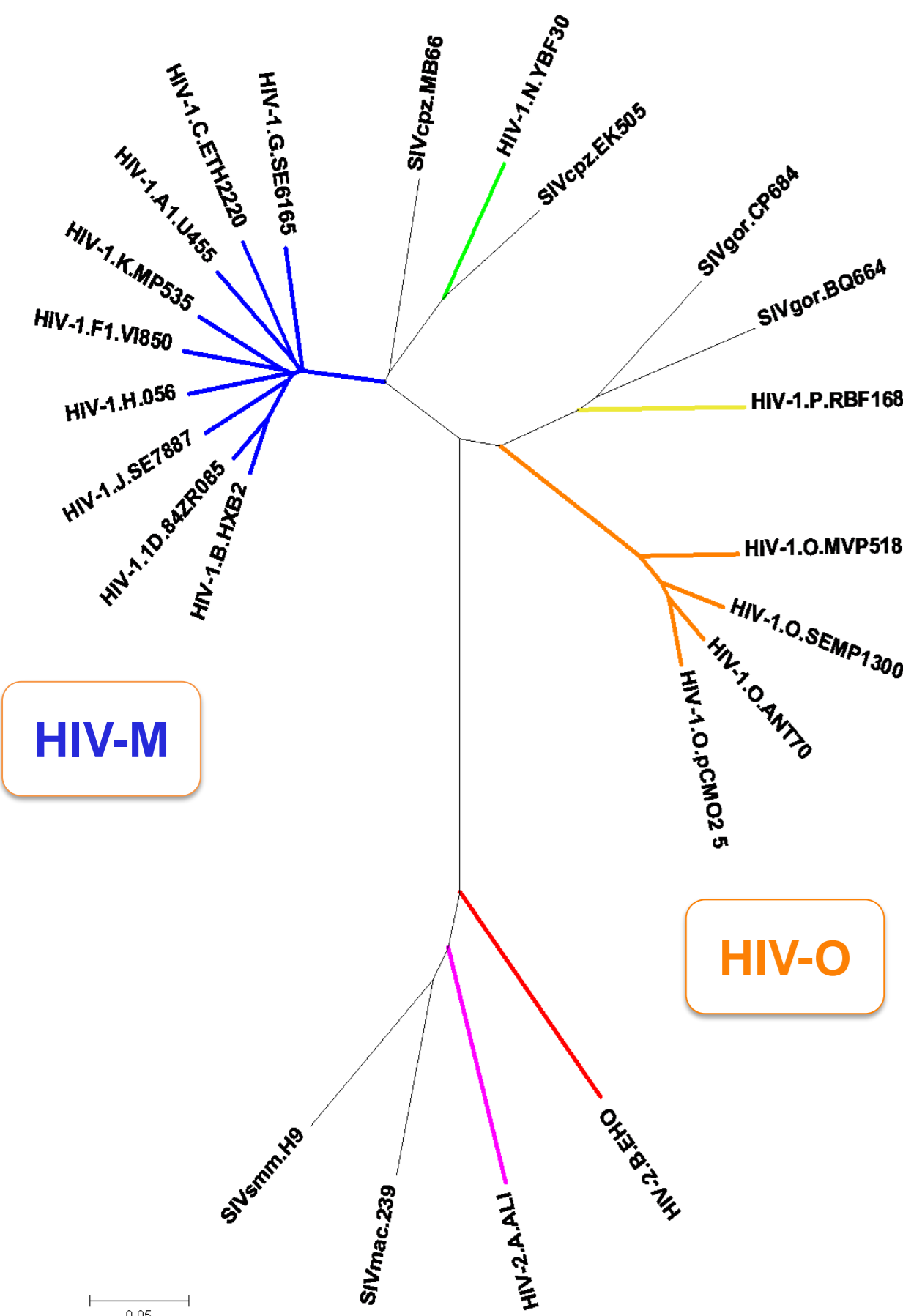

## OBJECTIVE

To explore HIV-1 group O genetic diversity and evolution through the largest series of HIV-O sequences, from Cameroon (samples used for HIV-O diagnosis and follow-up in the Centre Pasteur du Cameroun), France (RES-O surveillance network of the HIV National Reference Center) and Gabon.

## METHODS

**190 patients**: 102 from France + 87 from Cameroon + 1 from Gabon



Sampling times ranging from **1987 to 2012** (25 years)

Three genome regions amplified, sequenced and concatenated (2012 bp)

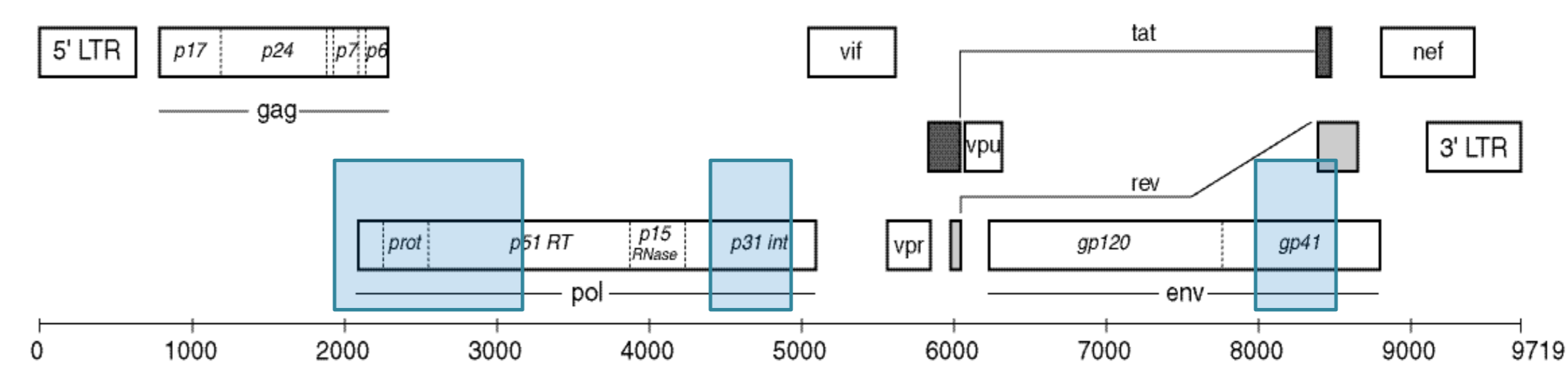

Maximum Likelihood Tree Inference

Distribution of Natural Y181C Resistance Mutation

Evolutionary Analyses (tMRCA and Bayesian Skyline)

## RESULTS

HIV-1 group O ML tree topology is atypical, with a **predominant clade** emerging from and broad and genetically diverse base population. The **natural presence** of the Y181C mutation, conferring **resistance to NNRTIs**, is significantly associated to the **emergent clade** ( $p < 0.01$ ).

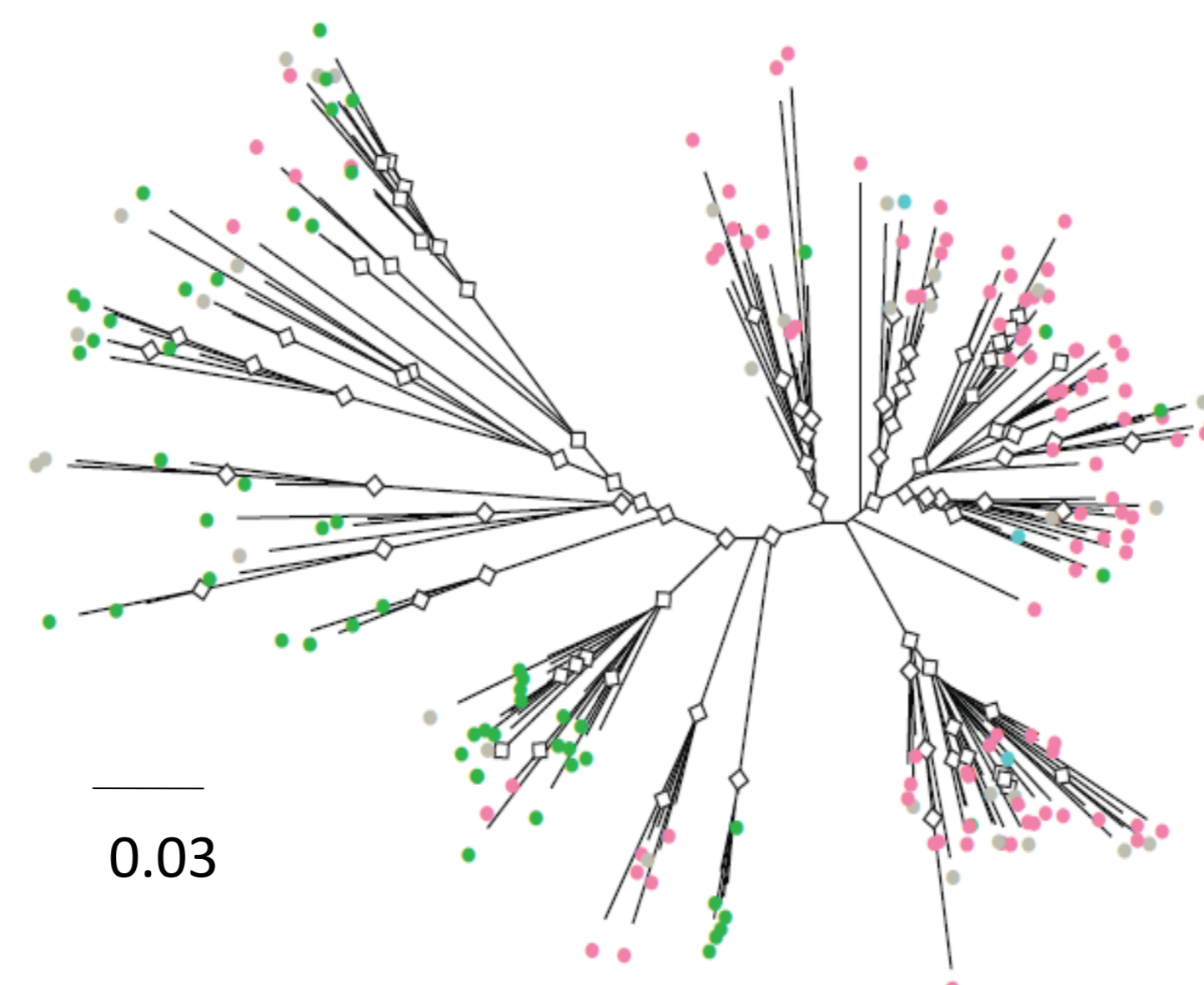

- Sequence from NNRTI-naïve patient with 181C residue
- Sequence from NNRTI-naïve patient with 181Y residue
- Sequence from NNRTI-treated patient or no data on ARV treatment

HIV-1 group O MRCA is estimated **around 1930** (black curves). The **predominant clade** is more recent, with a MRCA estimate around 1960 (blue curves). Several subclusters emerged even more recently, in the 1980's (yellow, green and red curves).

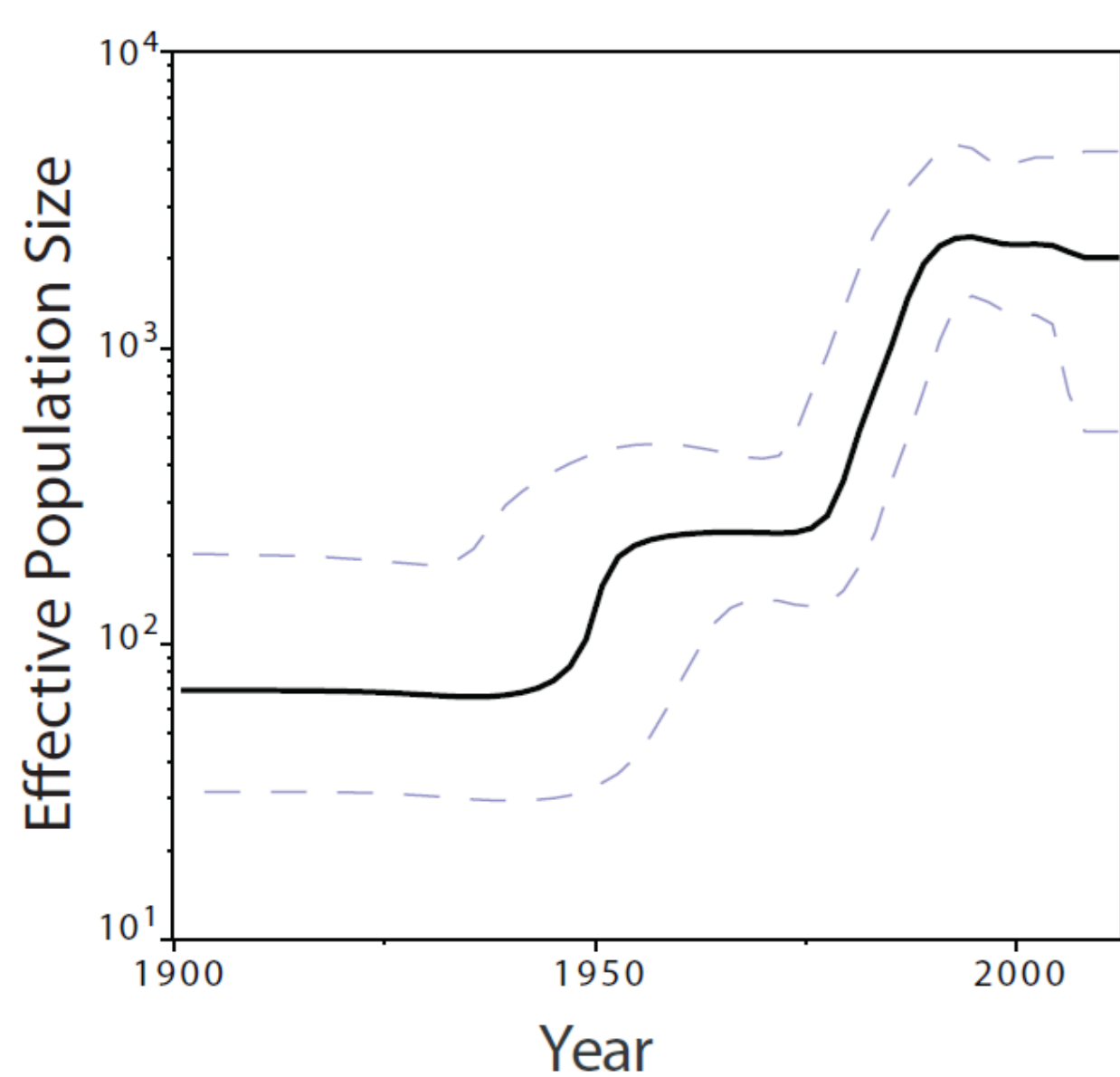
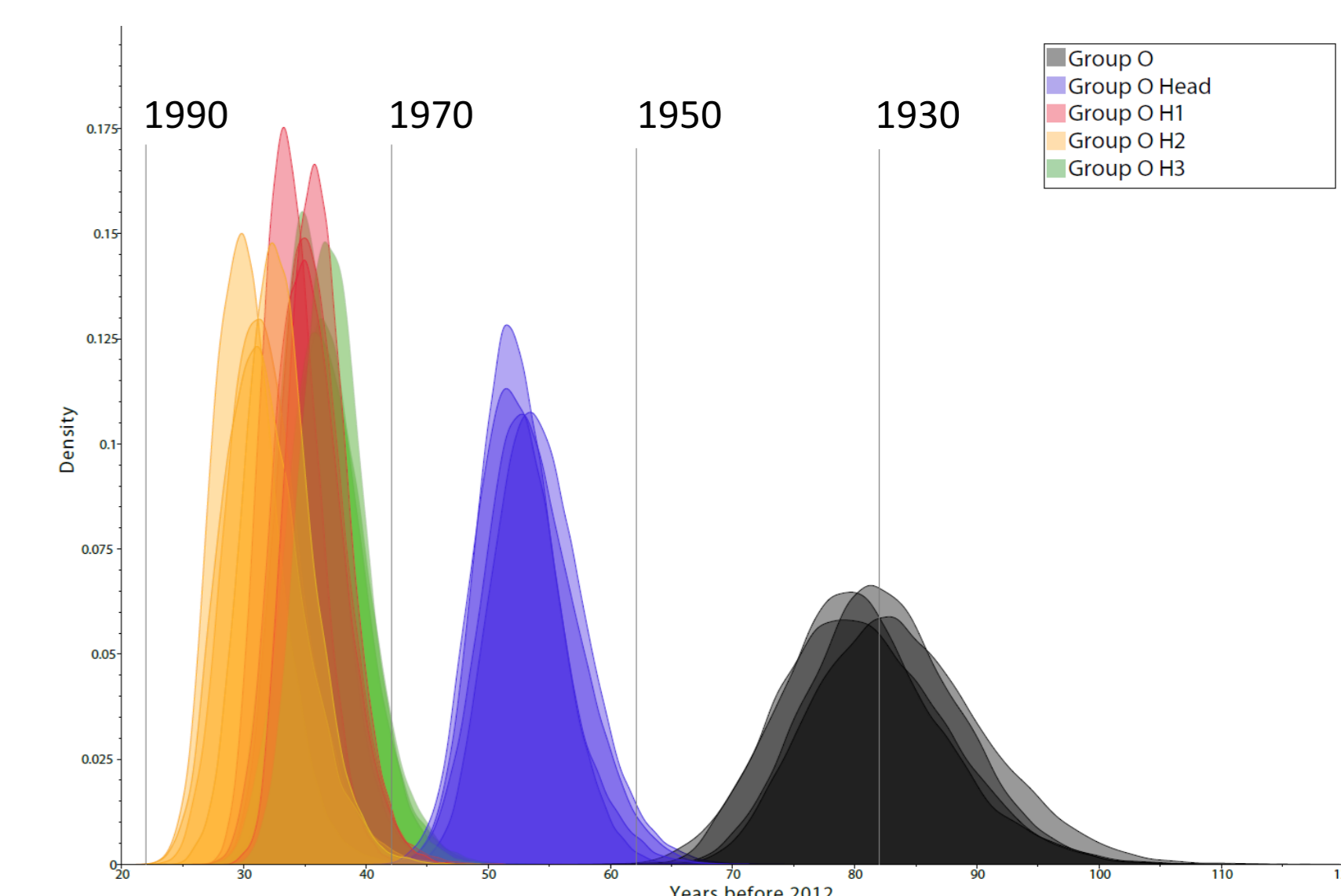

HIV-1 group O diversification went through **two exponential phases**, in the 1950's and in the 1980's.

The now **predominant population** arose during the second phase, from an **ancestral level** of genetic diversity which had developed during the first diversification wave.

According to the historical context in Cameroon, the 1<sup>st</sup> wave might have been favored by **iatrogenic** routes of transmission in the 1950's, while the second would have benefited from the development of **urbanization**.

## CONCLUSIONS

HIV-1 groups M and O share a **similar age** but group O has remained largely **confined to Cameroon**.

Group O local diversification resulted in a **broad genetic diversity** that cannot be compared to group M subtypes. However, **two subgroups** can be observed, corresponding to **two successive phases of diversification**.

The viral properties of the two subgroups need to be investigated, in order to better understand why the **most recent population** to emerge has now become **predominant**.